



# TC5809 Bracket Kit Installation Instructions

Serial Number

The TC35270 steering control is recommended for use with this bracket kit.

1. Set front wheels of vehicle in straight ahead position.

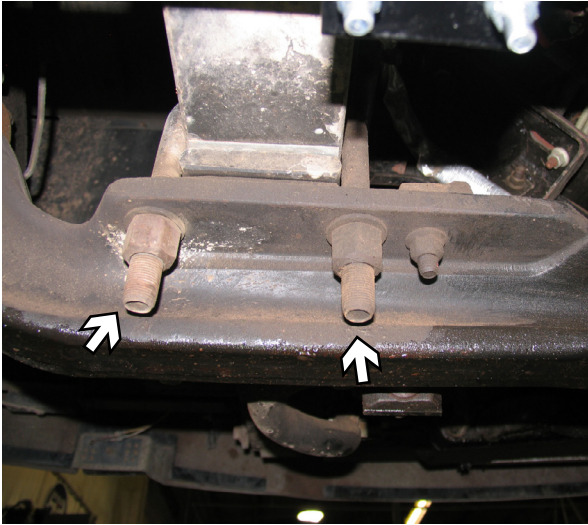

2. Remove two nuts from the driver's side axle pad.

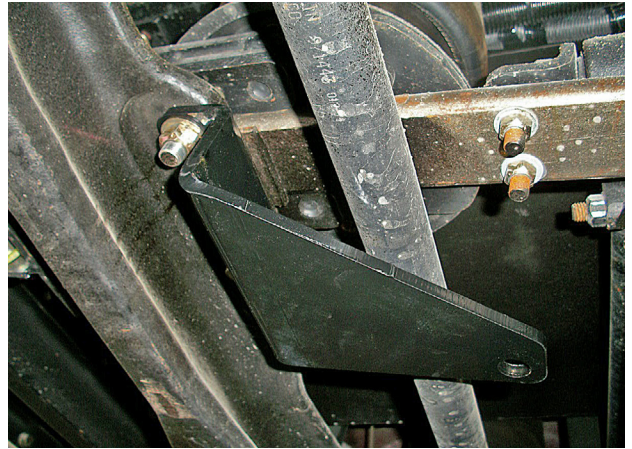

3. Slide the Anchor Bracket (Item 2) on the axle on the driver's side. The plate offsets toward the center of the vehicle. Reinstall the existing washers and nuts and tighten to manufacturers specifications. Bracket must clear tie rod at least 1/4".



4. Install Tie Rod Bracket (Item 3) on the passenger's side tie rod using the appropriate U-Bolts for your application (Item 4 - 1 7/8" or 2"), according to drawing on page 3. **DO NOT TIGHTEN.** *Tie Rod Bracket may be rotated or flipped to insure Steering Control (Item 1) remains parallel to the ground.*

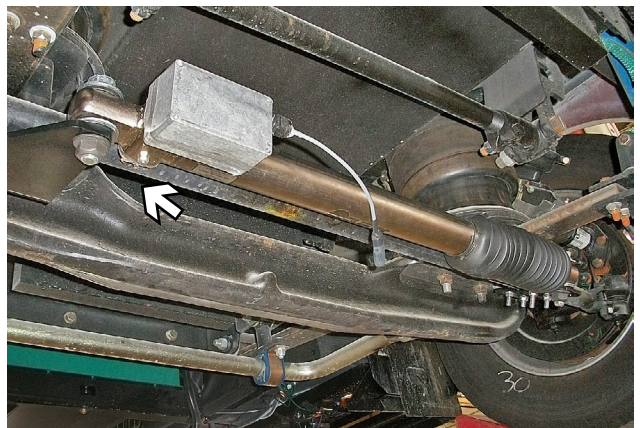

5. Install solenoid end of the TruCenter (Item 1) to the top side of the Anchor Bracket (Item 3) with 3 1/2" bolt, 3/4" flat washers and 1.59 flange nut (Items 5, 6 and 9), according to drawing on page 3.

© 2011 Blue Ox  
One Mill Road, Industrial Park  
Pender, Nebraska 68047  
Phone 402-385-3051  
Toll Free 888-425-5382  
Fax 402-385-3360  
www.blueox.com

6. Tighten bolt, washers and nut (Items 5, 6 and 9) on Anchor Bracket (Item 2) to 180-200 ft/lbs of torque.
7. Install small end of TruCenter unit (Item 1) to top of Tie Rod Bracket (Item 3) with 3 1/2" bolt, 3/4" flat washers and 1.59 flange nut (Items 5, 6 and 9), see drawing on page 3. Allow enough slack for the Tie Rod Bracket (Item 3) to rotate for alignment to the tie rod. DO NOT FULLY TIGHTEN.
8. Tighten U-bolts (Item 4) on the Tie Rod Bracket (Item 3) to 25-35 ft/lbs of torque, while maintaining an even amount of threads extending past each nut.
9. Tighten bolt washers and nut (Items 5, 6, and 9) on the Tie Rod Bracket (Item 3) to 180-200 ft/lbs of torque.

**Note: Check to be sure installed unit clears all other parts of vehicle by turning steering wheel to both extreme right and left positions. If unit scrapes or binds at any point, make necessary corrections by rotating unit on tie rod to obtain necessary clearance. It may also be necessary to dump the air from the air suspension to insure that the RV's trac bar and fuel tank to not come in contact with the TruCenter. If needed the solenoid end of TruCenter can then be mounted on the opposite side of the TruCenter.**

10. Install TruCenter Steering Control wiring according to instructions included in its package.

**11. DEALER OR INSTALLER: BE CERTAIN USER RECEIVES INSTRUCTION SHEET.**

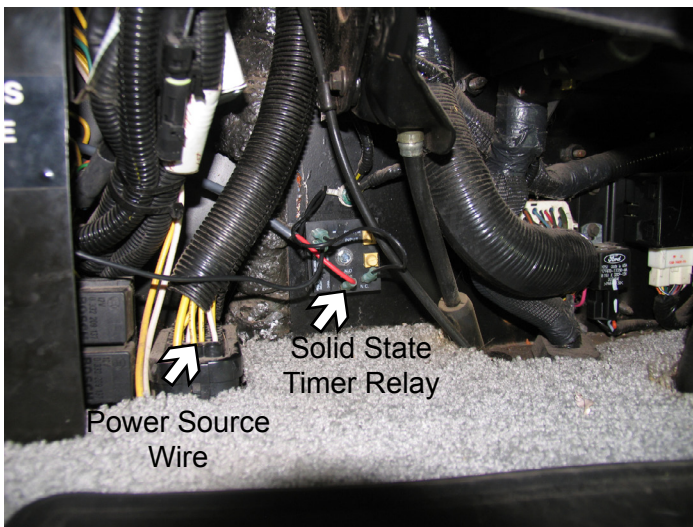

Insure that you use the proper TruCenter steering control unit for your application. Using too strong or too weak of a steering control may result in improper or undesirable handling.

**Product Safety Policy Statement:**

It is, and shall continue to be, a primary objective of Blue Ox Towing Products to provide customers with safe and reliable products. Blue Ox will, and has, established safety procedures in product design, manufacture, promotion and sales; and will coordinate efforts to promote customer safety to the greatest extent possible. Each department has a primary responsibility for the promotion of safety under the guidelines of the Product Safety Committee.

**If the TruCenter is in an accident, it must be replaced. DO NOT use it again! An accident can cause unseen damage and using it again could result in more damage or serious injury. DO NOT use the TruCenter if it is damaged or missing parts.**

© 2011 Blue Ox  
 One Mill Road, Industrial Park  
 Pender, Nebraska 68047  
 Phone 402-385-3051  
 Toll Free 888-425-5382  
 Fax 402-385-3360  
 www.blueox.com

## Tools Required

9/16" Socket

1 1/8" Socket

1 1/8" Wrench

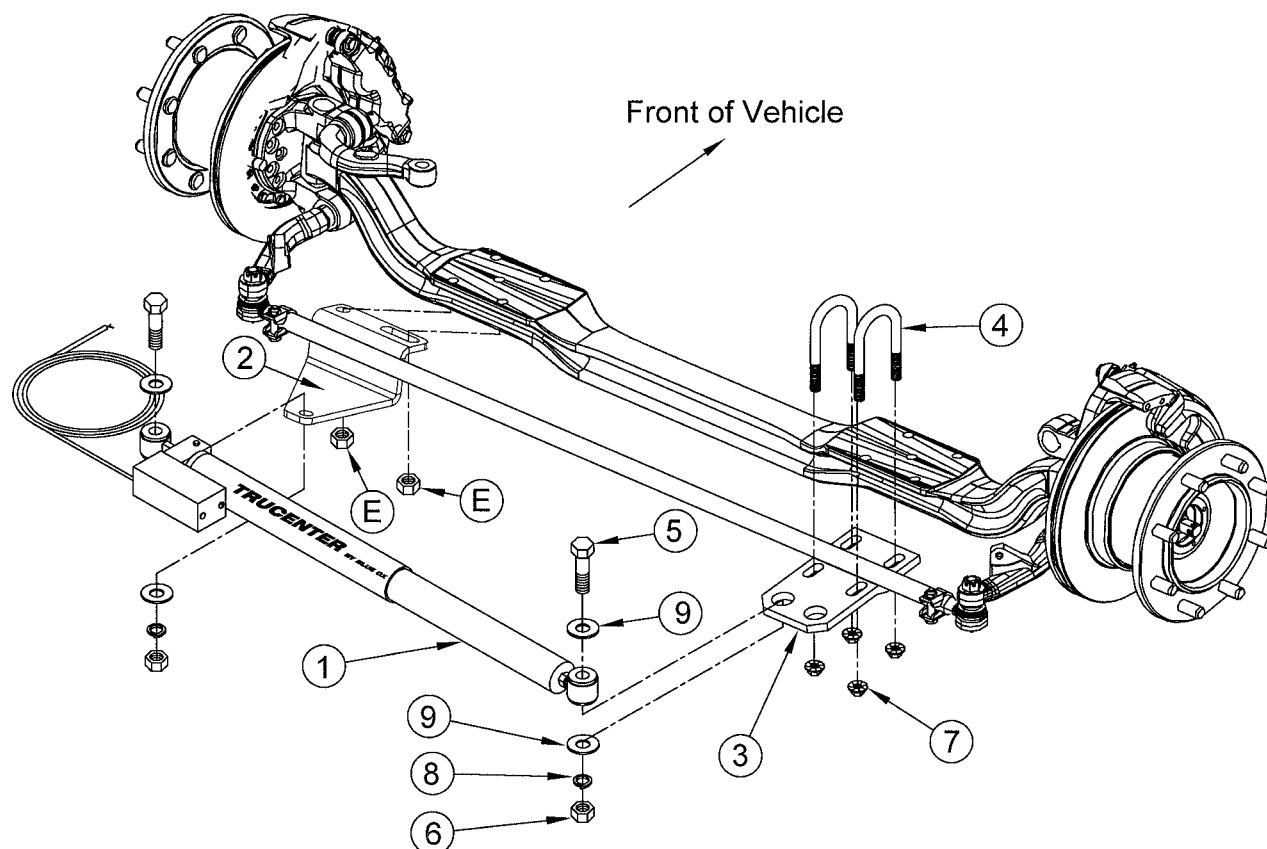

## Parts List

Ref. No.	Qty.	Part No.	Description
1	1	TC35270	TruCenter, Steering Control
2	1	101-7701	Plate, Anchor Bracket, TC5809
3	1	102-6344	Bracket, Tie Rod, 208
4	2	63-2751	U-Bolt, 1 7/8"
		<b>OR</b>	
4	2	63-2752	U-Bolt, 2"
5*	2	201-0780	Bolt, 3/4-10 X 3 1/2", 1.59IN Flange
6*	2	202-0180	Nut, 3/4-10, 1.59 Flange, Grd. 8, ZP
7	4	202-0174	3/8-16, Cent. Dimp. Flng, Nut, ZP
8*	2	203-0014	3/4" Lock Washer, ZP
9*	2	203-0007	3/4" Flat Washer, ZP
E	2		Existing Nuts

\* items are provided with TC35270

**IMPORTANT:** Use only genuine factory replacement parts on your bracket kit. Do not substitute homemade or nontypical parts. If a bolt is lost or in need of replacement, for your safety and the preservation of your bracket kit, be sure to use a replacement bolt of the same grade. Repair parts may be ordered through your nearest **Blue Ox** dealer or distributor.



© 2011 Blue Ox  
 One Mill Road, Industrial Park  
 Pender, Nebraska 68047  
 Phone 402-385-3051  
 Toll Free 888-425-5382  
 Fax 402-385-3360  
 www.blueox.com